

BHR-16HP "Energy Tank"™

General Piping Connections

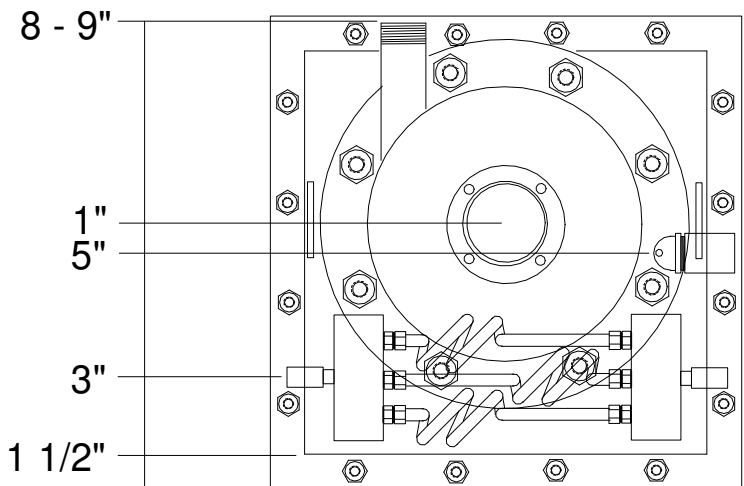
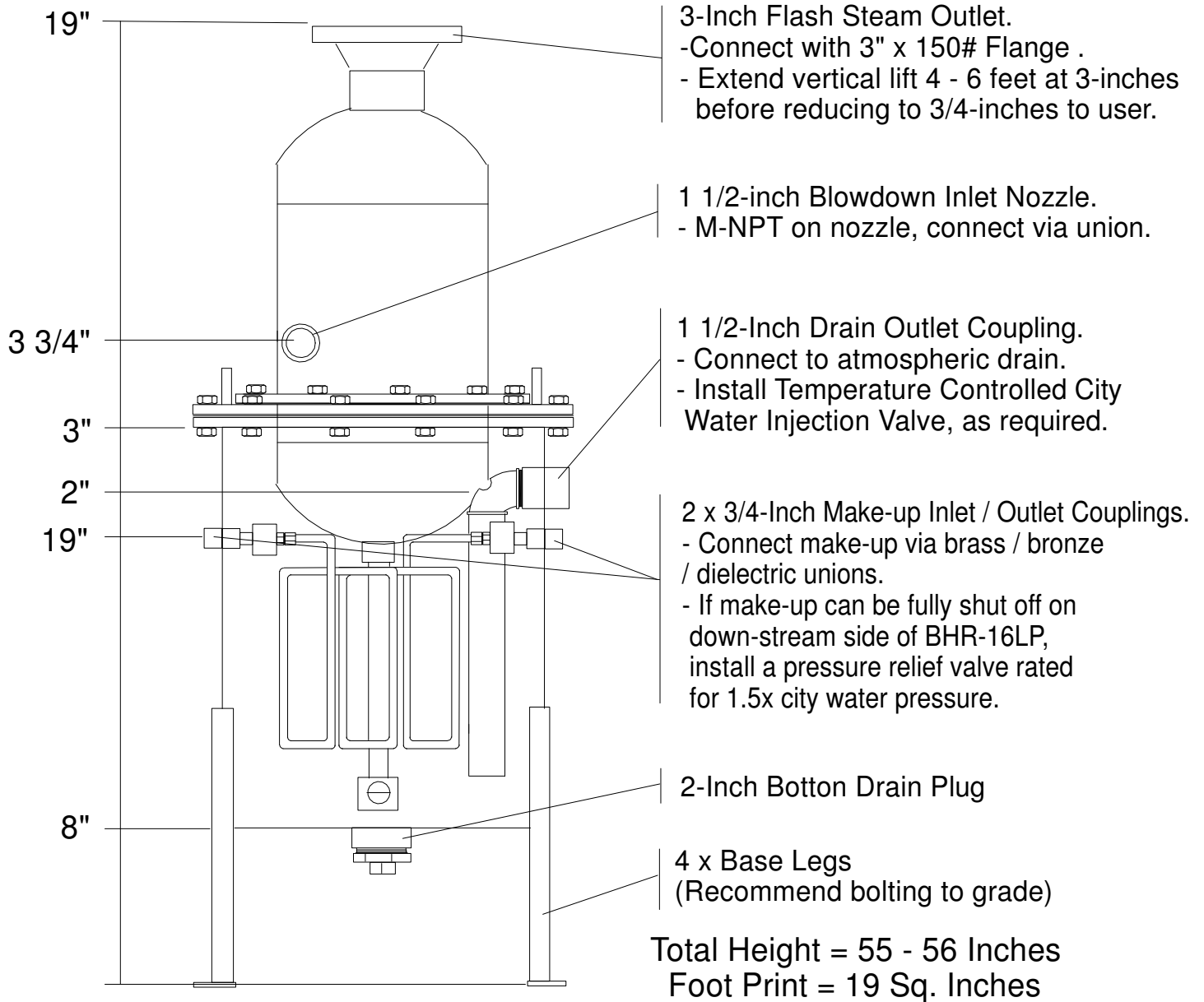

BHR-HX-3 Heat Exchanger

- 2 x 3/4-inch Inlet and Outlet SS Couplings
- 2 x 5-inch x 2-inch SS Manifolds
- 3 x 3/8-inch 304 SS Coils in 10-foot lengths

Patented Process: USA # 6,938,583 Canada # 4,414,611